

ENGLISH

Introduction	3
Care and maintenance	3
Features	4
General features	4
Technical specifications	4
Audio	4
Wireless connectivity	4
TWS technology compatible with	4
Audio input	4
FM radio	4
MicroSD and USB player	4
Battery	4
Product content	5
General overview	5
Main Functions	6
Switching on and off the device	6
Playback modes	6
Bluetooth --> microSD --> USB --> Audio-in	6
Playback control	6
Bluetooth (BT)	6
True Wireless Stereo (TWS)	7
Removable storage units (USB sticks/MicroSD cards)	7
FM radio	8
Auxiliary audio input	8
Call control (Hands-free function)	8
Voice Assistant	9
Charging the battery	9
Reset	9
Firmware update	9
Warranty	9
Declaration of conformity	9

ENERGY♥SYSTEM



urban box 5+

Manual de usuario / User manual
Manual de l'utilisateur / Manual do usuário

Introduction

- Thank you for trusting our company and buying the new *Urban Box 5+*. We hope you enjoy it.
- Stereo speaker with Bluetooth 5.0 and True Wireless Stereo technology to pair two units simultaneously and enjoy music with twice as much power.
- Double membrane delivering enhanced bass.
- USB/MicroSD MP3 player, FM radio and audio-in.
- Before you start using your *Urban Box 5+*, we strongly recommend reading this manual to get used to it.

Care and maintenance

- Do not expose your *Urban Box 5+* to impacts, dust, humidity or high temperatures.
- Use neither corrosive nor abrasive cleaning products.
- Do not disassemble the device. All repair works should be carried out exclusively by qualified staff of Energy Sistem Technology, S.A.
- Please make sure your *Urban Box 5+* is off when you are not using it. Do not store the device with an empty

battery for long periods.

Features

General features

- Have fun with this speaker that combines style and functionality. Listen to music via Bluetooth 5.0, TWS, MP3 player or FM radio.
- True Wireless Stereo technology makes it possible to pair two speakers and get twice as much power.
- Speaker coated with splashproof fabric, available in bright colours.
- Hands-free function to answer your calls wirelessly.
- 20 W power.
- Play the MP3 files from your microSD cards or USB memory sticks (up to 64 GB capacity).
- 10 hours of battery life to enjoy music from dawn to dusk.

Technical specifications

Audio

- System: 2.0
- Power: 20 W
- 2 x 2.25-inch full range speakers
- Passive radiator: two membranes
- Frequency response: 80 Hz ~ 18 kHz
- Signal/Noise ratio: > 60 dB

Wireless connectivity

- Bluetooth 5.0, class II. Up to 20 m distance range.
- Compatible Bluetooth profiles: HSP / HFP / A2DP / AVRCP
- Frequency band: 2.4 GHz (2.402 ~ 2.480 GHz).
- Maximum output power: < 20 dBm
- Hands-free function. Microphone sensitivity: -42 dB
- True Wireless Stereo (TWS) technology

TWS technology compatible with

- Urban Box 5+

Audio input

- 3.5 mm mini jack stereo audio-in (AUX)

FM radio

- Frequency band: 87.5 ~ 108 MHz
- Automatic tuning

MicroSD and USB player

- MicroSD and USB decoder: reads MP3 and WAV files stored on 64 GB external units with FAT/ FAT32 file system.

Battery

- Capacity: 3000 mAh
- Type: lithium polymer
- Battery life: up to 10 hours*
- Charging port: USB Type-C
- Charging time: 2 hours

Important: *The battery life depends on the selected volume level and the type of music.

Product content

- Urban Box 5+
- USB Type-C cable
- Quick guide
- Pouch
- Strap

General overview

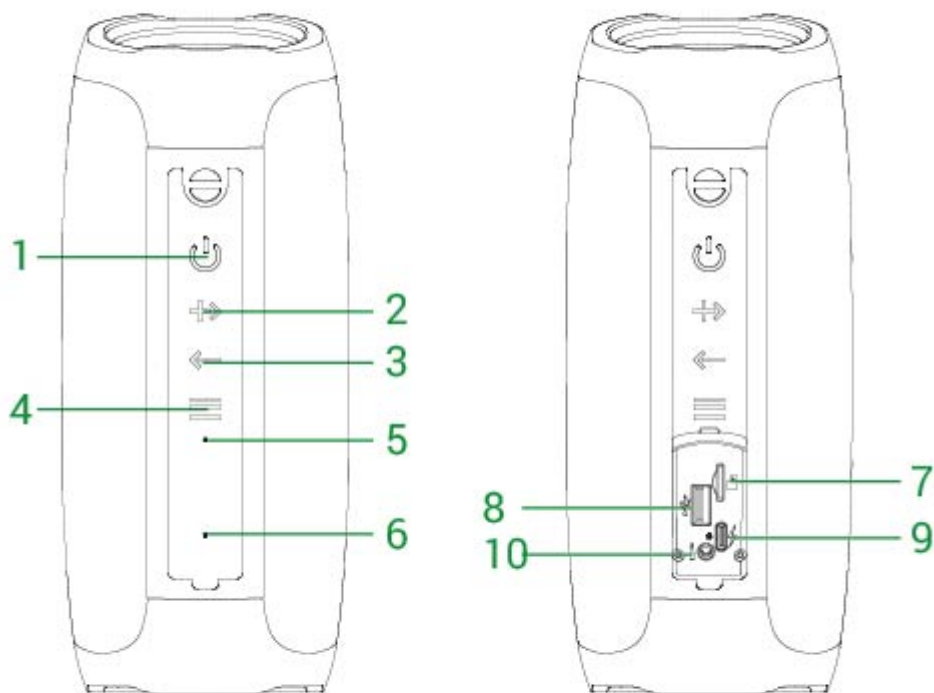

1. On/Off/Play/Pause/Calls
2. Volume +/Next
3. Volume -/Back
4. Playback mode/Voice assistant
5. Microphone
6. LED indicator
7. MicroSD card slot
8. USB port
9. USB Type-C charging port
10. Auxiliary audio input

Main Functions

Switching on and off the device

To switch on your *Urban Box 5+*, press and hold *On/Off/Play/Pause/Calls (1)* for 2 seconds. At this point, you will hear a confirmation sound. The *LED indicator (6)* lights up blue.

To turn off the device, press and hold *On/Off/Play/Pause/Calls (1)* for 2 seconds. You will also hear a confirmation sound. At this point, the *LED indicator (6)* switches off.

Important: To force the device to shut down, press the hidden reset button located inside the *Auxiliary audio input (10)*.

Playback modes

Once the *Urban Box 5+* is on, you can choose the playback mode you prefer. To do so, press *Playback mode/Voice assistant (4)* repeatedly until finding the preferred playback mode. Playback modes will appear in the following order:

Bluetooth --> microSD --> USB --> Audio-in

You will also hear the word identifying each mode.

Playback control

Select a playback mode and you will be able to control all playback functions from your *Urban Box 5+*.

Press *On/Off/Play/Pause/Calls (1)* to play or pause a song.

Press *Volume +/Next (2)* or *Volume -/Back (3)* to adjust the volume level according to your preferences. You will hear a warning sound when reaching the maximum volume.

Press and hold *Volume +/Next (2)* or *Volume -/Back (3)* for 2 seconds to skip to the previous or next track.

When using a removable storage unit such as a USB stick or microSD card, you only have to press *Playback mode/Voice assistant (4)* twice to skip to another folder. To enable shuffle mode, press and hold the very same button for 2 seconds. You will hear a confirmation sound every time you enable/disable shuffle mode.

Important: Bear in mind that you can only manage playback from the connected music player while using the *Auxiliary audio input (10)*.*

Bluetooth (BT)

To pair your speaker with a Bluetooth device, press *Playback mode/Voice assistant (4)*. Select Bluetooth mode. At this point, the *LED indicator (6)* flashes blue. You will hear a confirmation sound when the device enters search mode.

At this point, access the Bluetooth settings on the connected device and search for *Urban Box 5+* among the detected devices. Select it to establish the connection. The devices will be connected immediately. You will hear a sound confirming both devices are correctly paired.

Your *Urban Box 5+* connects to the last paired device automatically when you switch it on once again, provided that the Bluetooth connection on the source device is enabled.

Your *Urban Box 5+* turns off automatically after 5 minutes in Bluetooth mode, if not paired with any device.

The Bluetooth wireless connection range is up to 20 metres.

True Wireless Stereo (TWS)

This option makes it possible to wirelessly connect another *Urban Box 5+* and hear music with twice as much power. This way, you will create a stereo sound system made up of two different channels: left and right.

To use this function for the first time, turn on both *Urban Box 5+*. Enable Bluetooth mode on both units. At this point, the *LED indicators (6)* on both speakers will flash blue.

Press and hold *Playback mode/Voice assistant (4)* for two seconds on any of them. You will hear a confirmation sound. The *LED indicator (6)* stops flashing and glows blue on the other speaker.

Pair the first speaker with your smartphone. At this point, you will be able to start Bluetooth playback. You will hear the music through both speakers at the same time. One speaker will be assigned the left channel (L) and the other one the right channel (R).

The next time you turn on both speakers, they will pair with one another automatically, provided that Bluetooth mode is enabled on both units.

If you want to disable this function, press and hold *Playback mode/Voice assistant (4)* for 2 seconds on any of them. Both speakers will be disconnected.

Skip to the next/previous track and adjust the volume from any speaker while TWS mode is enabled. If you turn up the volume on any of the speakers, you will be turning up the volume of both of them at the same time.

Important: *To use this function, Bluetooth mode must be enabled. In all other playback modes (USB, microSD or AUX-in) a TWS connection is not possible.*

Removable storage units (USB sticks/MicroSD cards)

The *Urban Box 5+* plays .mp3 and .wav files from 64 GB USB sticks or microSD cards with FAT / FAT32 file system. Plug the microSD card into the *MicroSD card slot (7)* or the USB stick into the *USB port (8)*. The speaker plays the contents automatically a few seconds after inserting the storage unit.

If you turn off the *Urban Box 5+* or select another playback mode, the internal memory will save the moment where you paused playback. This way, music playback will always resume from the last track you listened to.

Press *On/Off/Play/Pause/Calls (1)* to play or pause a song.

Press *Volume +/Next (2)* or *Volume -/Back (3)* to adjust the volume level according to your preferences. You will hear a warning sound when reaching the maximum volume.

Press and hold *Volume +/Next (2)* or *Volume -/Back (3)* for 2 seconds to skip to the next or previous track.

Press *Playback mode/Voice assistant (4)* twice to skip to another folder.

To enable or disable shuffle mode, press *Playback mode/Voice assistant (4)* for 2 seconds. You will hear a confirmation sound every time you enable/disable this mode.

The root folders and files of your removable microSD cards and USB sticks will be read in chronological order and the songs included in your folders in alphabetical order.

Here you have a diagram of the reading order:

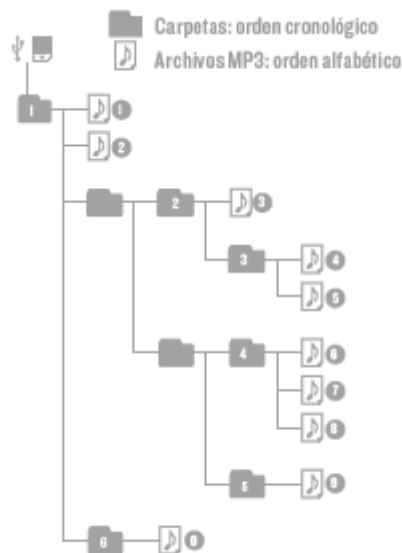

FM radio

Before using the FM radio function, it is necessary to carry out a search of all stations available. The radio stations will be saved to the speaker's internal memory. It is therefore not necessary to carry out a new search each time you switch it on. You will only have to do this if you place the device in a new location or if you change the frequency of the saved radio station.

To carry out a search of all radio stations, press *Playback mode/Voice assistant* (4), until the FM radio mode appears on screen. Press and hold *Playback mode/Voice assistant* (4) for 2 seconds to carry out an automatic search. The process may take a few minutes.

Once the search has been completed, press and hold *Volume +/Next* (2) or *Volume -/Back* (3)* to select the radio station you want to hear from all saved radio stations. Press the very same buttons to turn the volume up or down.

Press *On/Off/Play/Pause/Calls* (1) to mute the radio. Press the very same button to unmute.

If you place the speaker somewhere else, you will have to carry out a new search to obtain a proper radio wave reception.

Your *Urban Box 5+* saves the last selected radio station when you turn it off. This way, you will hear it when switching on the speaker once again.

Important: *The battery charging process may interfere with the radio signals depending on the AC/DC power adapter used.*

Auxiliary audio input

Your *Urban Box 5+* features an *Auxiliary audio input* (10) to connect your external devices using an audio cable with 3.5 mm mini jack plug.

Important: *It is not possible to manage music playback from the speaker while using this mode. You will have to use the connected music player instead.*

Call control (Hands-free function)

You can control your calls from the speaker itself. To do so, pair the *Urban Box 5+* with your smartphone.

When receiving a call, the song you are listening to stops and the ringing tone sounds instead. Press *On/Off/Play/Pause/Calls (1)* to answer the call. Press it once again to hang up.

Important: If you receive an incoming call while TWS mode is enabled, you will only hear the voice of the person who calls through the speaker connected to your smartphone.

Voice Assistant

The *Urban Box 5+* allows you to activate your smartphone's voice assistant. You only have to press *Playback mode/Voice assistant (4)* twice. This way, you will directly activate your smartphone's assistant via Bluetooth.

This function will let you ask questions and use voice commands to perform tasks naturally and easily.

For more information you can take a look at Google Assistant and Siri user guides, available on their manufacturers' websites.

Charging the battery

When the battery level is below 10%, you will hear a sound reminding you to charge it. To charge the battery, plug the USB Type-C end of the provided USB cable into the *USB Type-C charging port (9)* and the other USB end to any device with a 5 V USB port (PC, USB wall charger, car charger, etc.). The LED of the *USB Type-C charging port (9)* lights up red and switches off once the charging process has been completed.

The speaker has an approximate battery life of 10 hours. It depends on the selected volume and the type of music.

The charging time is approximately 2 hours.

Important:

- Use a 5 V 2 A AC/DC power adapter.
- Do not leave your *Urban Box 5+* completely discharged for a long time.

Reset

To force the device to shut down, press the hidden reset button located inside the *Auxiliary audio input (10)*.

Note: Avoid using metallic objects when performing the reset.

Firmware update

Download the last version [here](#)

Warranty

You can check the warranty terms here:

<https://www.energysistem.com/terms-warranty>

Declaration of conformity

Issuer's name: Energy Sistem Technology, S.A. - CIF: A53107488

Address: C/ Calpe, 1 - 03509 Finestrat, Alicante (Spain)

Tel: +34 966 830 324

We declare under our sole and exclusive responsibility that the product:

Description: Bluetooth speaker
Brand: Energy Sistem
Model: Urban Box 5+
Manufacturer: Energy Sistem Technology, S.A.
Manufacturing country: China

referred to in this declaration complies with the essential norms and standards:

EN62368-1:2014+A11:2017
EN 62479:2010
ETSI EN 301 489-1 V2.2.3 (2019-11)
ETSI EN301 489-17 V3.2.3 (2020-07)
ETSI EN 301 489-52 V1.1.0 (2016-11)
ETSI EN 300 328 V2.2.2 (2019-07)
ETSI EN 303 345 V1.1.7 (2017-03)

in conformity with the provisions of the Directive 2014/53/EU of the European Parliament and of the Council of 16th April 2014.

Finestrat, 1st September 2020



Miguel Ángel Aragüez García
Innovation and Technology Director

