

ENGLISH

Product content	3
General characteristics	4
Bluetooth® wireless connection	4
MicroSD Memory Control (External)	5
FM Radio Control	5
Voice Assistant	6
Force device disconnection (Reset)	6
Care and Maintenance	7
Technical specifications	7
Audio	7
Bluetooth® wireless connection	7
FM radio	8
External memory reader	8
CABLE	8
Hands-free microphone	8
Battery	8
Other	8
Warranty	8

ENERGY♥SYSTEM



Manual de usuario / User manual
Manual de l'utilisateur / Manual do usuário

starlit radio/ radio color/ headtuner

Thank you for trusting us and purchasing your new *ECO BT Headphones*. We hope you enjoy it.

We advise you to read this user manual to get the most out of the product.

Product content

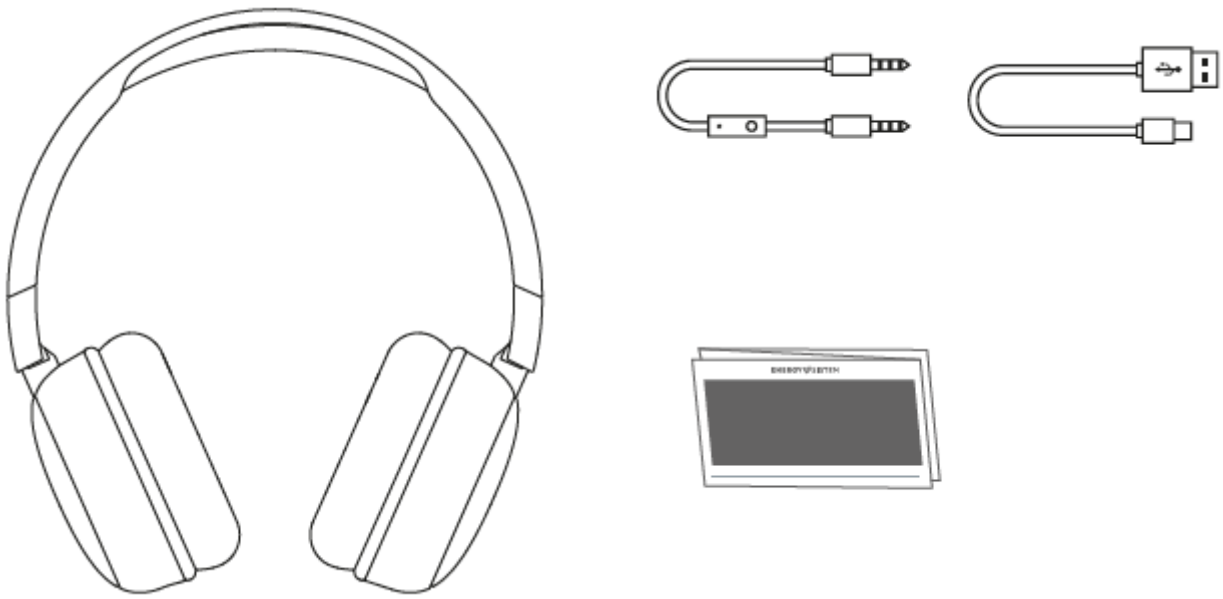

General characteristics

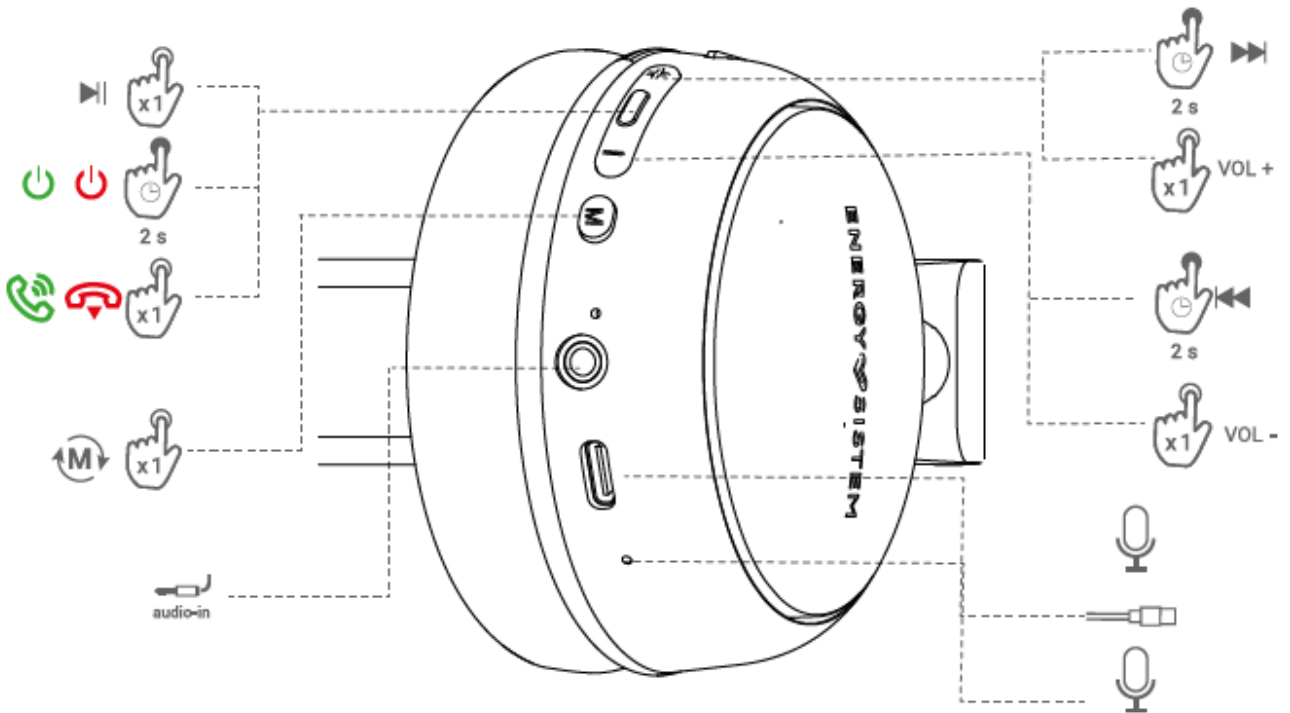

Bluetooth® wireless connection

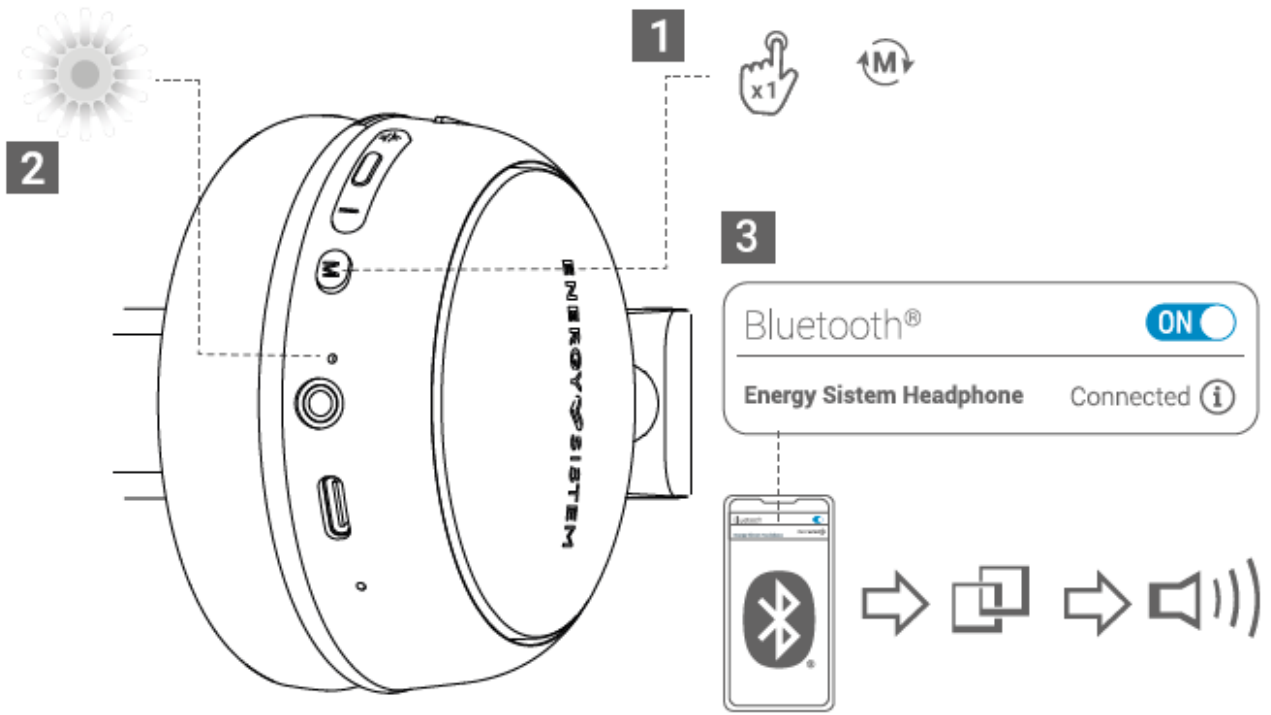

MicroSD Memory Control (External)

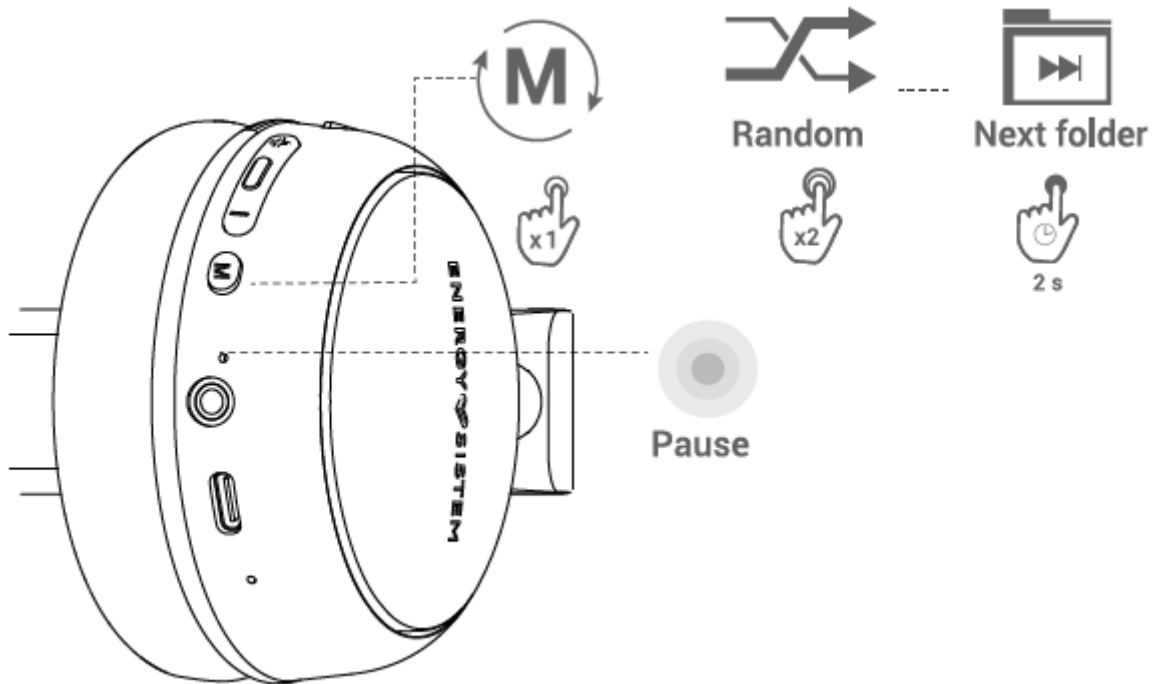

FM Radio Control

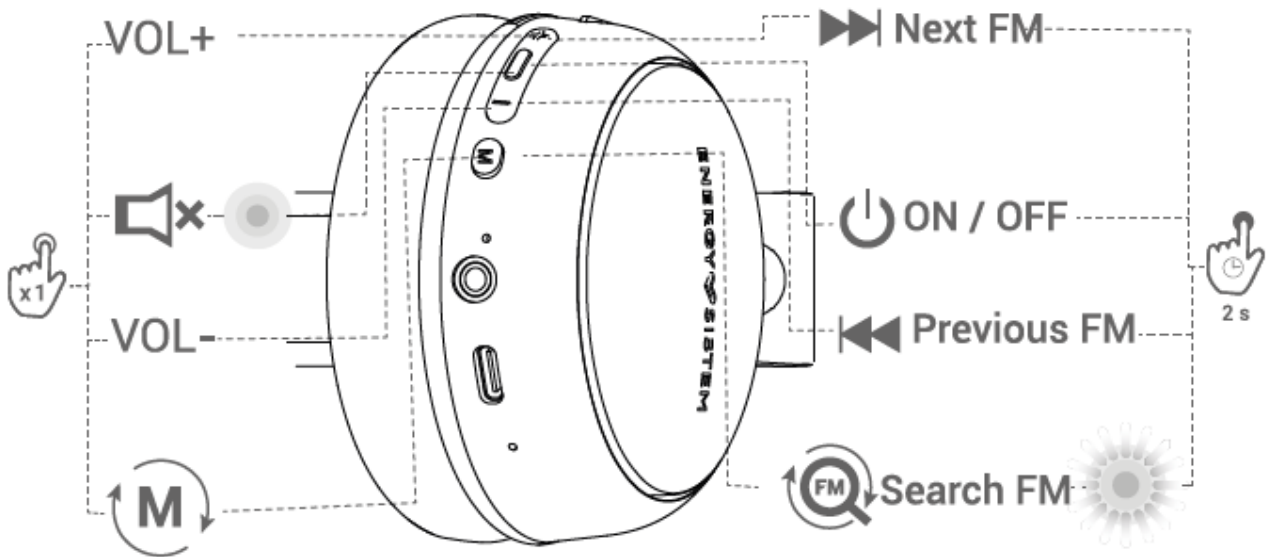

Voice Assistant



Note: * In order to optimise battery life.

- In order to optimise battery life, do not store or leave the device unused for a long period of time with a fully discharged battery.
- When you connect the charging cable the headset will turn off and start charging. It is not possible to charge and use the headset at the same time for safety reasons related to current CE regulations.

Caution: Do not charge your headphones with fast charging adapters or dedicated laptop charging adapters, as their output voltage exceeds 5V and the device may become unusable.

Force device disconnection (Reset)

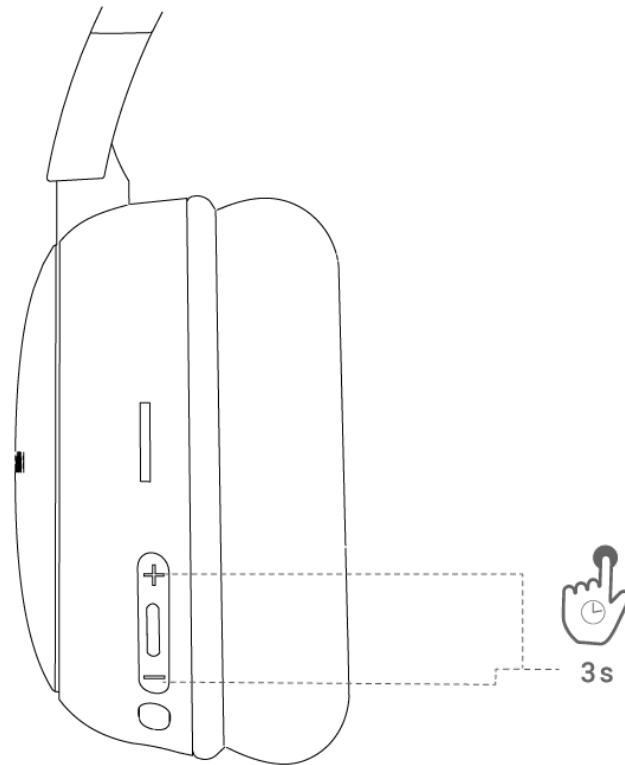

Care and Maintenance

- Do not expose the headphones to shock, dust, moisture or high temperatures.
- Do not use corrosive or abrasive cleaning agents.
- Keep the headphones clean and dust-free by using a soft, dry cloth.
- Do not disassemble the headphones. Any repair must be carried out exclusively by qualified Energy System Technology, S.A. personnel.
- Do not leave the battery completely discharged for a long period of time.

Technical specifications

Audio

- Frequency response: 20 Hz ~ 20 kHz
- Driver diameter: 40 mm
- Design: Circumaural
- Type: dynamic
- Impedance: 32 Ohm

Bluetooth® wireless connection

- Bluetooth® version 5.3, class 2
- Operating frequency: 2.4 GHz
- Maximum signal strength: < 20.00 dBm
- Supports Bluetooth® HSP / HFP / A2DP / AVRCP profiles
- Compatible with SBC codecs
- Up to 20 metres range
- Hands-free function
- Google/Siri compatible voice assistant

FM radio

- Working frequency: 87.5 ~ 108 MHz
- Auto search function

External memory reader

- Micro SD decoder: plays MP3 / WAV files from external memory sticks up to 128 GB capacity in FAT / FAT32 format

CABLE

- Length: 120 cm
- Conector: mini jack 3,5 mm

Hands-free microphone

- Type: Built-in
- Sensitivity: -38 dB \pm 3 dB (@1 kHz)
- Frequency range: 10 Hz ~ 10 kHz

Battery

- Capacity: 400 mAh / 3.7 V
- Type: lithium polymer
- Battery life at medium volume: 16 hours*.
- Charging time: 1.5 hours
- Charging system: USB Type-C

Other

- Adjustable headband

*This is an approximate figure. Battery life depends on the volume selected and the type of music played.

Warranty

You can check the warranty conditions here:

<https://www.energysistem.com/condiciones-de-garantia>